

AL-GROUND MOUNTING SYSTEM

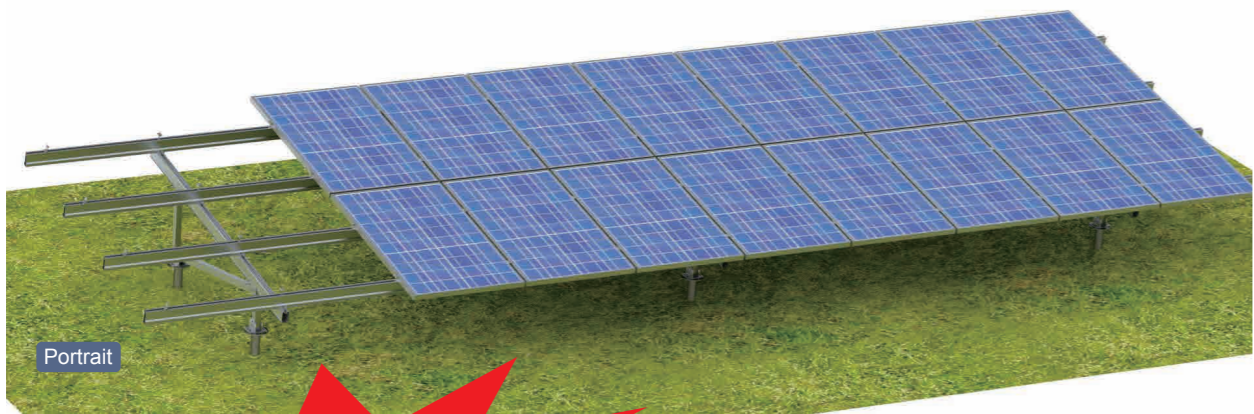

Focus on the details
Optimize the structure

Technical Information

Install Site	Open Field	Material	Aluminum Alloy & SUS A2 - 70
Tilt Angle	0-45°	Color	Natural Color, Black
Structure Height	<4m	Finishing	Anodizing
Max Wind Speed	60m/s	Fondation	Concrete Ground Screw
Snow Load	1.4KN/ m ²	Warranty	10 Year Quality Warranty
Standard	AS/NZ 1170, JIS C8955		



Introduction

New Main Rail

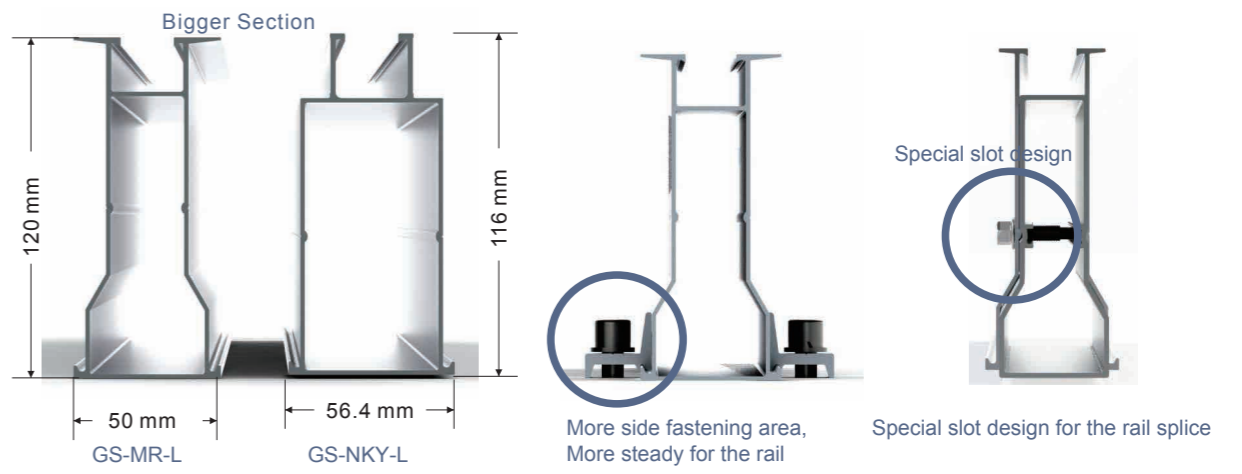

New Support Beam

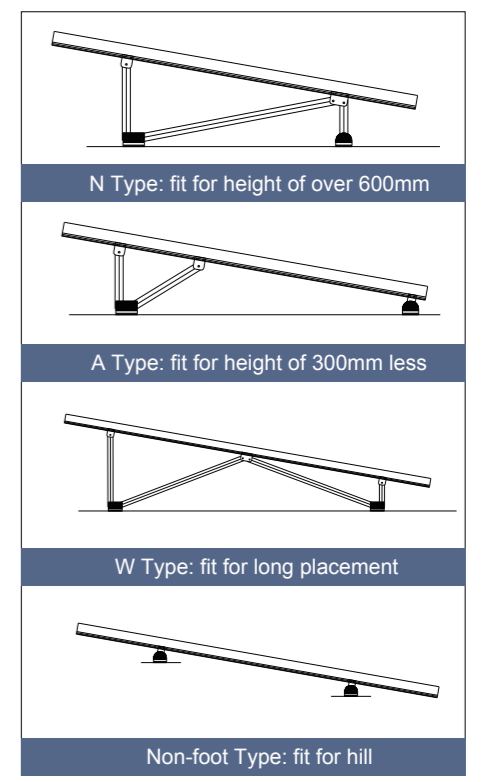
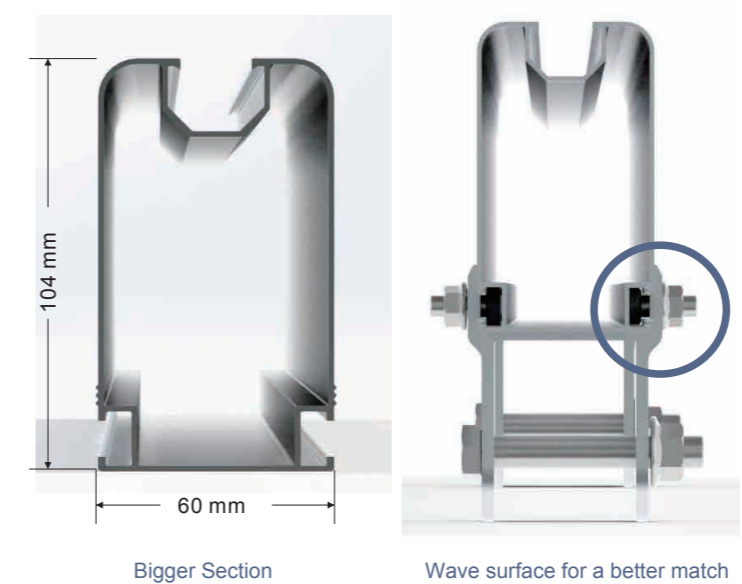

various structures for the different ground types

APPLICATION

Portrait Placement

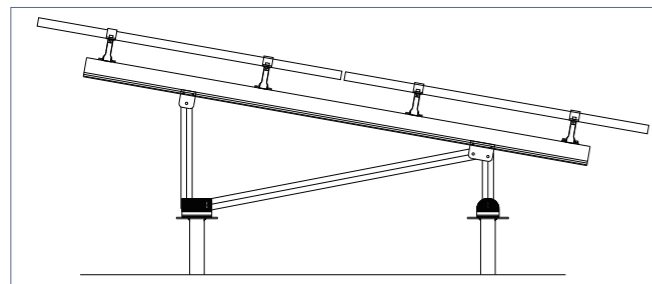
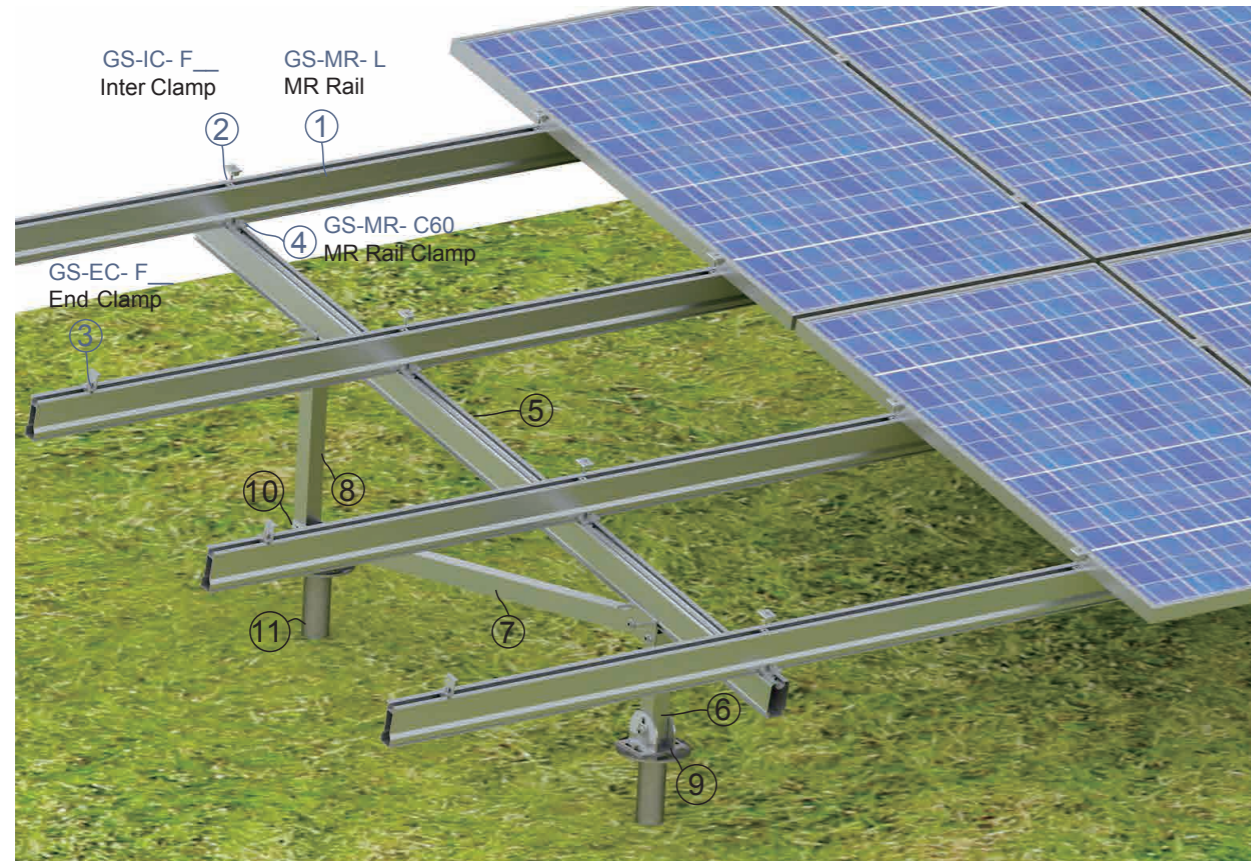

Pre-assembly in the factory to save time and labor cost.

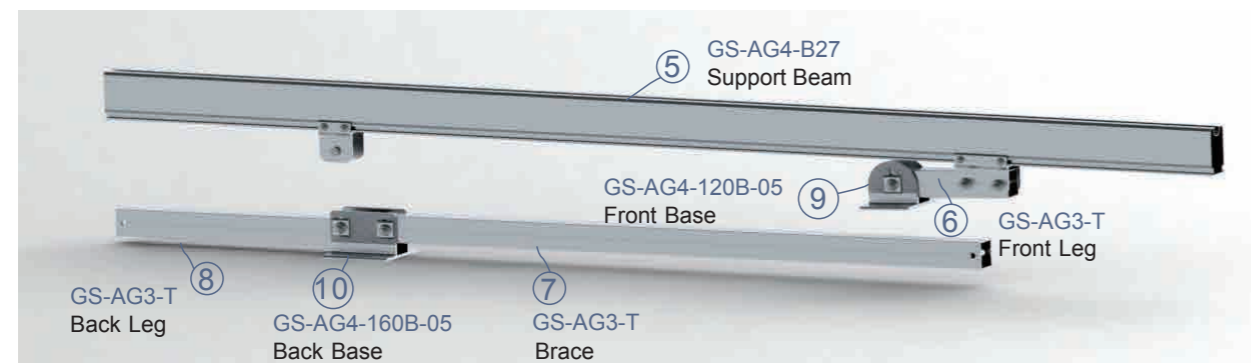

PROJECT EXAMPLE

Step 1: Project Information

Solar Panel Size:	1650x992x40mm
Tilt Angle:	30°
Module Orientation:	Portrait
Foundation:	Ground Screw Concrete

Flood Height:	500mm
Wind Speed:	40m/s
Unit Array:	2* 10(20pcs)

Step 2: Planning

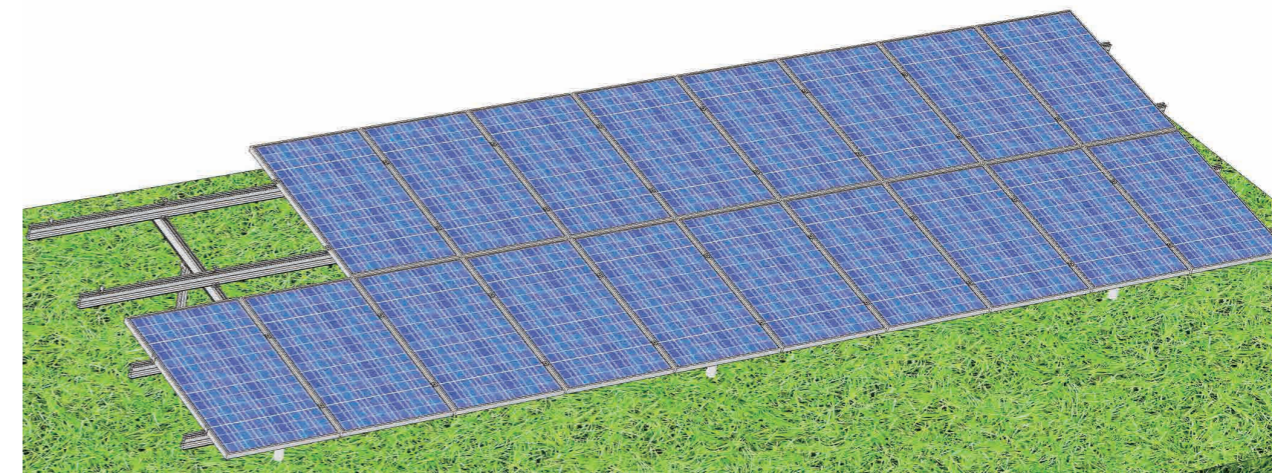

Step 3: Components List

Item	Description	Spec.	Qty	Package
GS-MR-5100	GS MR Rail 5100	5100mm	8 pcs	148pcs/pallet
GS-MR-SP	GS MR Rail Splice	400mm	4 pcs	9pcs/Box,2Boxes/CTN
GS-MR-C60	GS MR Rail Clamp	60mm	24 pcs	100pcs/Box,4Boxes/CTN
GS-IC-F40	GS Inter Clamp	40mm	36 pcs	100pcs/Box,4Boxes/CTN
GS-EC-F40	GS End Clamp	40mm	8 pcs	100pcs/Box,4Boxes/CTN
GS-AG4-B27A	AG4 Support Beam,2740mm	2740mm	3 pcs	Pre-assembly
GS-AG3-T-1150	AG 3 Leg, 1150mm	1150mm	3 pcs	
GS-AG3-T-950	AG 3 Leg, 950mm	950mm	3 pcs	
GS-AG4-160B-05	AG 4 Back Base-05	160mm	3 pcs	
GS-AG4-120B-05	AG 4 Front Base-05	120mm	3 pcs	
GS-F76C-1600-T3	Ground Screw	76x1600mm	6 pcs	160pcs/pallet

APPLICATION

Landscape Placement

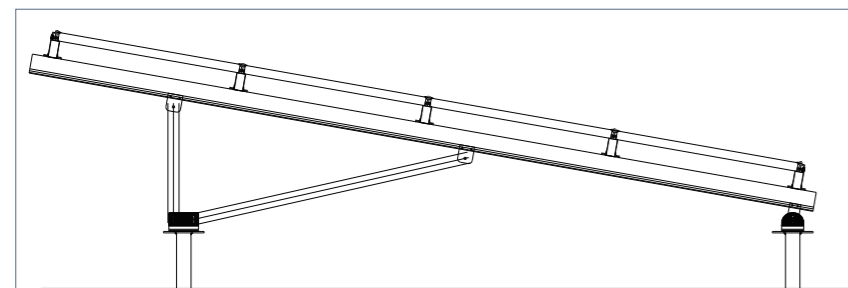
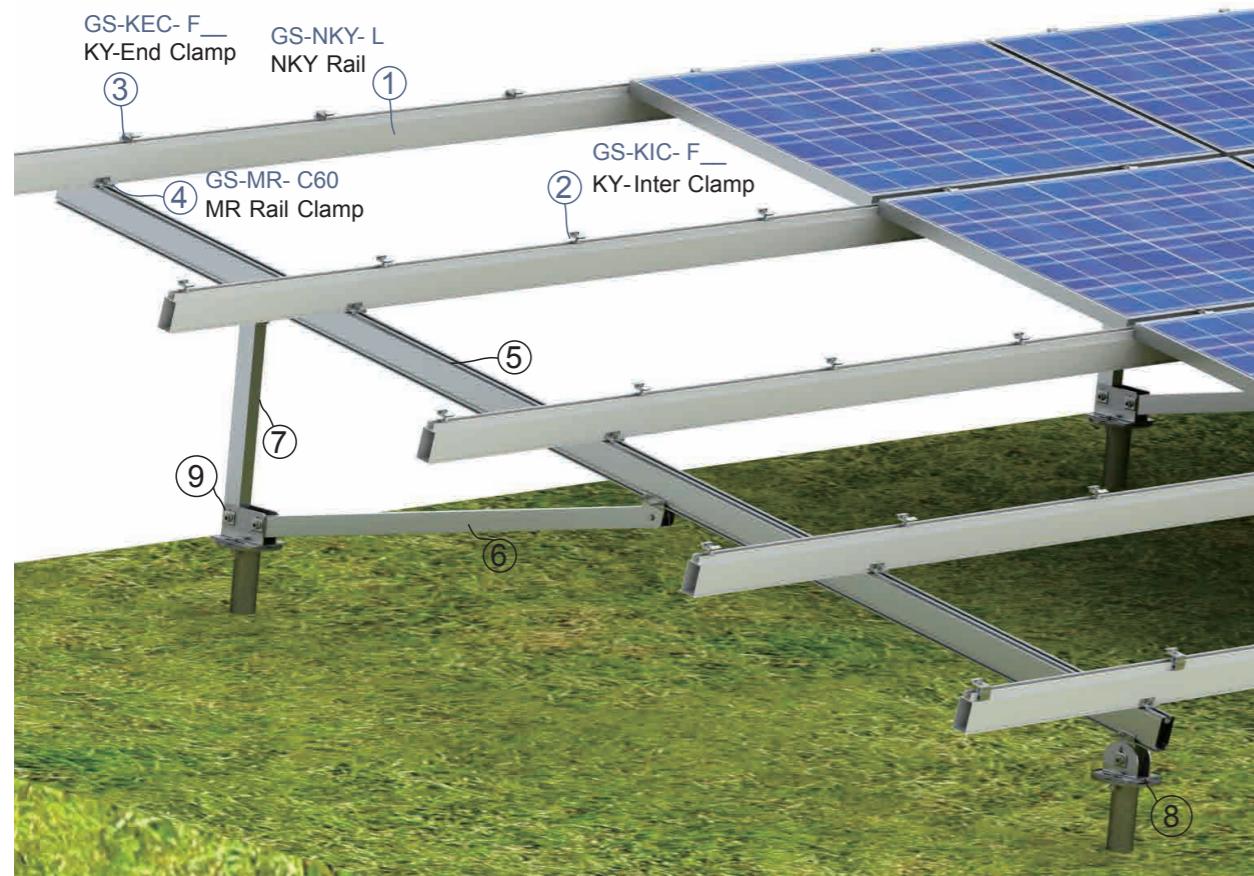

Pre-Assembly in the factory

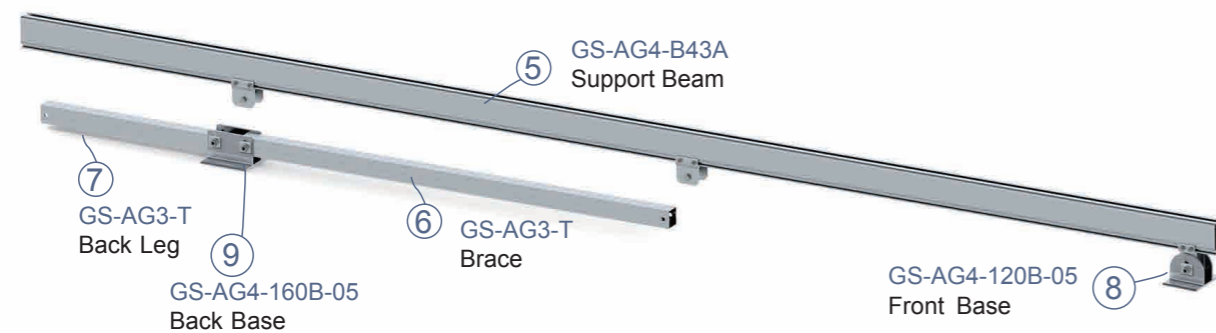

PROJECT EXAMPLE

Step 1: Project Information

Solar Panel Size:	1650x992x40mm
Tilt Angle:	30°
Module Orientation:	Landscape
Foundation:	Ground Screw Concrete

Flood Height:	500mm
Wind Speed:	40m/s
Unit Array:	4*6(24pcs)

Step 2: Planning

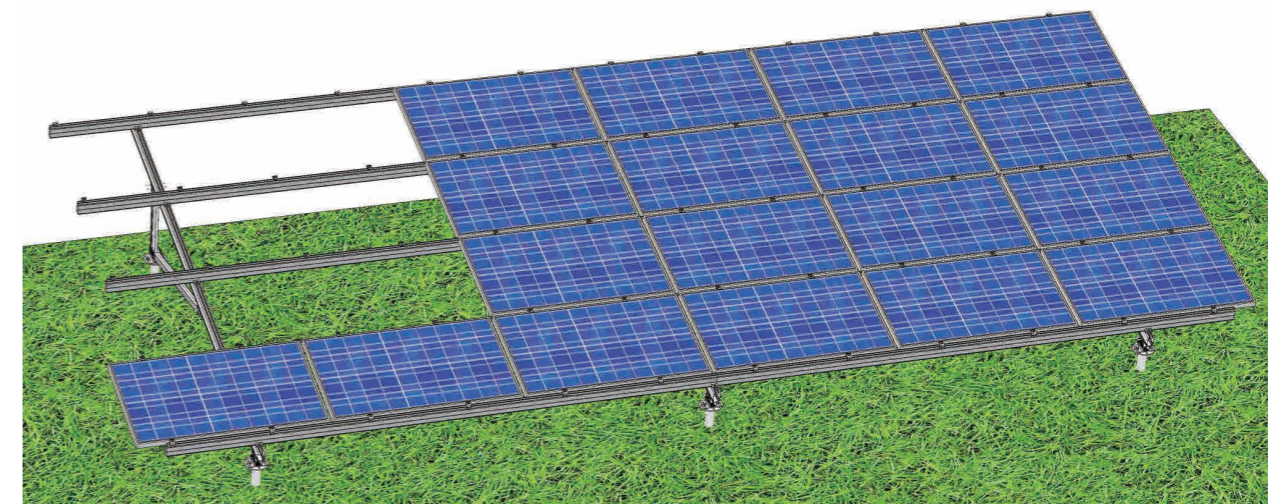

Step 3: Components List

Item	Description	Spec.	Qty	Package
GS-NKY-4800	GS NKY Rail 4800	4800mm	10pcs	128pcs/pallet
GS-NKY-SP	GS NKY Rail Splice	400mm	5pcs	6pcs/Box,2Boxes/CTN
GS-MR-C60	GS MR Rail Clamp	60mm	30pcs	100pcs/Box,4Boxes/CTN
GS-KIC-F35/40	KYR Inter Clamp	35-40mm	36pcs	100pcs/Box,4Boxes/CTN
GS-KEC-F40	KYR End Clamp	40mm	24pcs	100pcs/Box,4Boxes/CTN
GS-AG4-B43A	AG 4 Support Beam,4300mm	4300mm	3pcs	Pre-assembly
GS-AG3-T-1750	AG 3 Leg, 1750mm	1750mm	3pcs	
GS-AG3-T-1610	AG 3 Leg, 1610mm	1610mm	3pcs	
GS-AG4-160B-05	AG 4 Back Base-05	160mm	3pcs	
GS-AG4-120B-05	AG 4 Front Base-05	120mm	3pcs	
GS-F76C-1600-T3	Ground Screw	76x1600mm	6pcs	160pcs/pallet

Hill Application

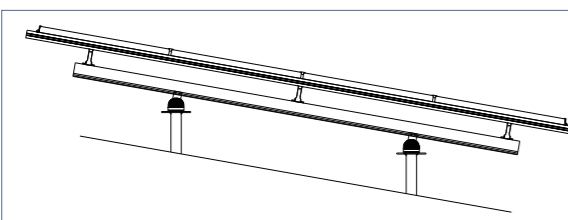
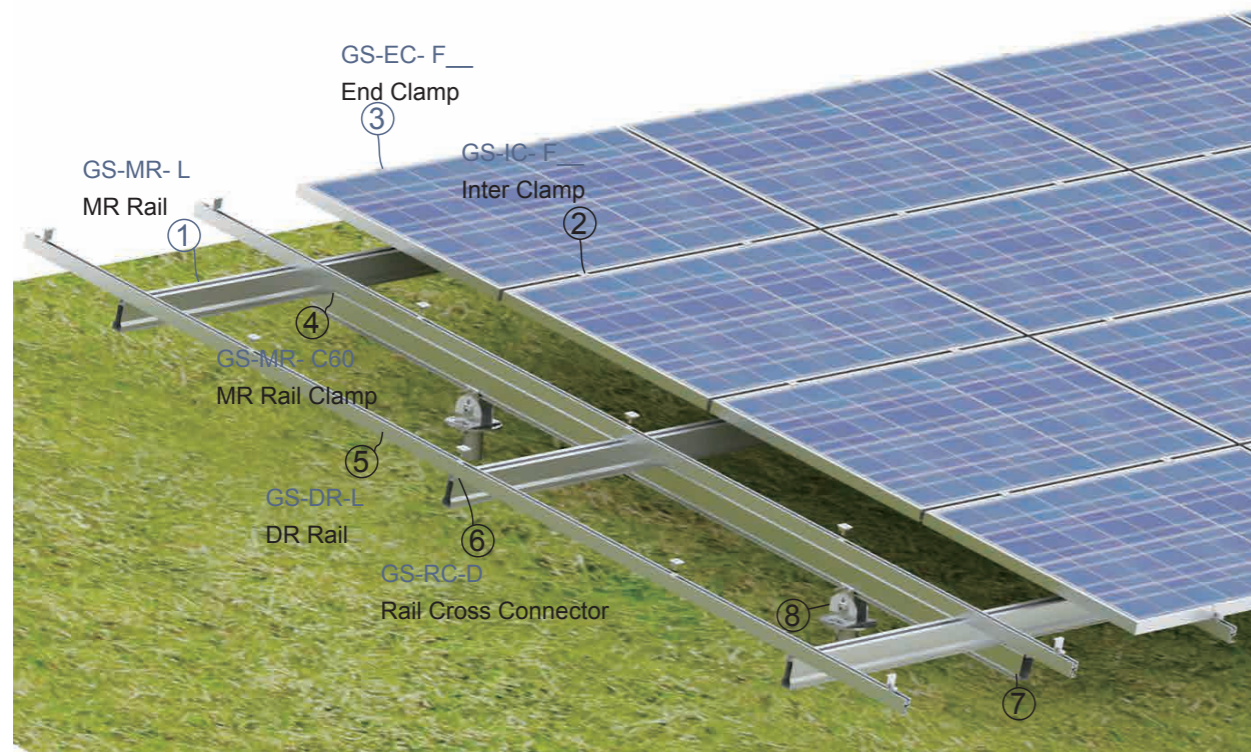

Pre-assembly in the factory

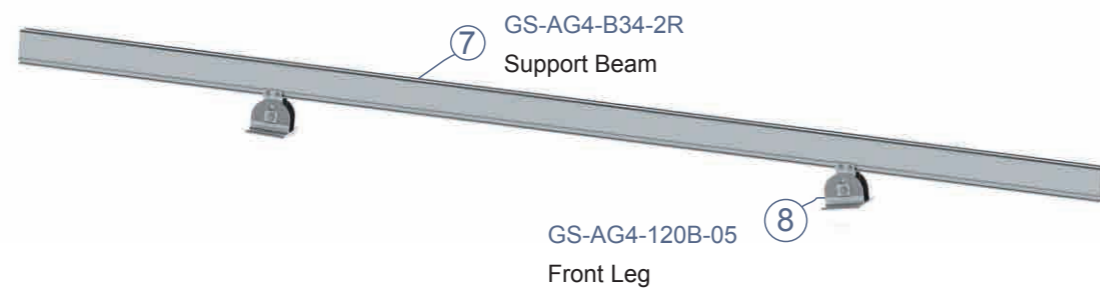

Golf Course Application

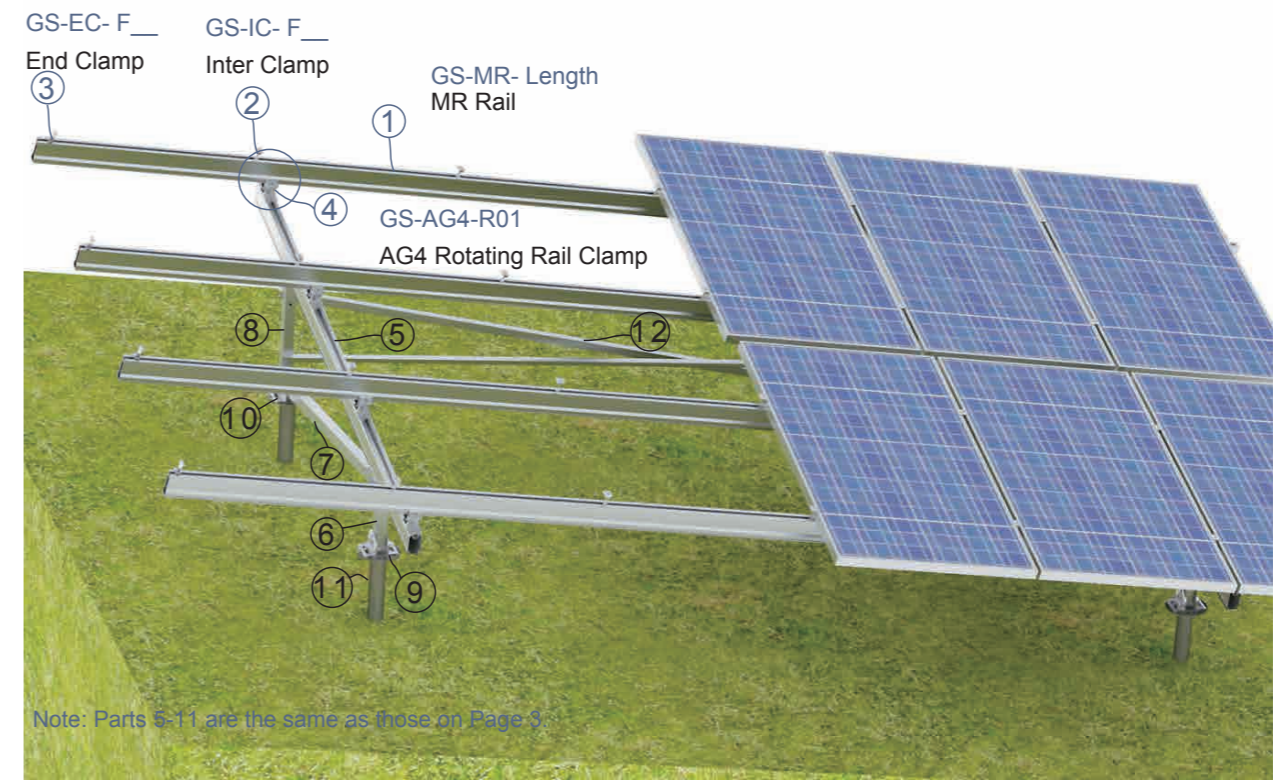

Note: Parts 5-11 are the same as those on Page 3

